



Product information

RB 200 and RW 200

Levelling bench and rolling machine for manual straightening and tensioning of band and gang saw blades

RB 200 and RW 200



Checking the tension curve.



Exact inspection of back straightness with straight edge and integrated light box.



Easily positioned, robust rolling unit. Roller pressure precisely adjustable via long lever arm.

The dressing bench RB 200 and roller unit RW 200 lets you straighten and tension band and gang saw blades up to a width of 400 mm and 200 mm respectively. A robust design, perfect results, simple operation and a high level of safety were key priorities in the development of this machine, and pay high dividends in day-to-day operation.

The rolling area is optimally protected by a switch bar, bringing the machine into line with the latest safety standards. The loading of the saw blade has been simplified in that the upper part of the rolling unit no longer has to be opened and closed, and the rolling pressure can be accurately regulated via the large, ergonomic clamping lever. The device also boasts a range of practical details as follows:

A large anvil plate in wear-free tool steel with vibration dampers, practical storage areas for measuring and machining tools, an integrated light box for inspecting the top straightness and extendable roller carriers.

The dressing bench can be expanded on a modular basis for machining band saw blades up to 18 m in length.

Technical data at a glance:

- Band saw blades
 - Blade width up to 400 mm
 - Blade length* 8.5 to 11.5 m
(*other lengths on enquiry)
- Gang saw blades
 - Blade width up to 200 mm
 - Tooth length up to 1500 mm
- Anvil plate (example)
 - Length 1200 mm
 - Width 320 mm
 - Weight 245 kg
- Roller unit
 - Adjusting range 390 mm
 - Rolling speed 5 to 16 m/min
- Connected load 1.4 kVA/1.2 kW
- Weight approx. 540 kg
(if using the above anvil plate)

Dimensions

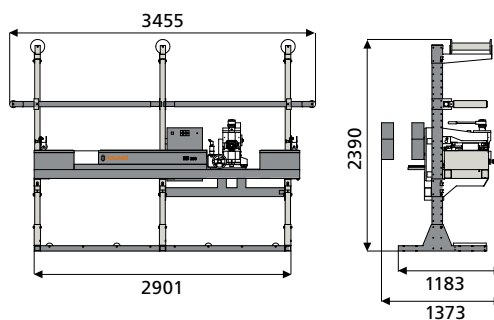

Highlights:

- Highly robust design.
- Axially mounted rollers from the tried-and-tested VOLLMER RC 100.
- Good ergonomic conditions thanks to adaptable working height.
- Top safety standards.
- Modular expansion potential.
- Extendable roller carriers (optional).
- Hold-down rollers for very twisted band saw blades (optional).

We reserve the right to make design modifications in the interests of technical improvement.